

**International Colloquium on
Scientific and Fundamental
Aspects of GNSS 2022**

14-16 September 2022, Sofia (Bulgaria)

GNSS Time Transfer Using High-Gain Antennas



Overview

1. Motivation
2. System description
3. Factory test
4. Field test
5. Time transfer error budget
6. Conclusions



Motivation and challenges

- Time Transfer = $T_A - T_B$

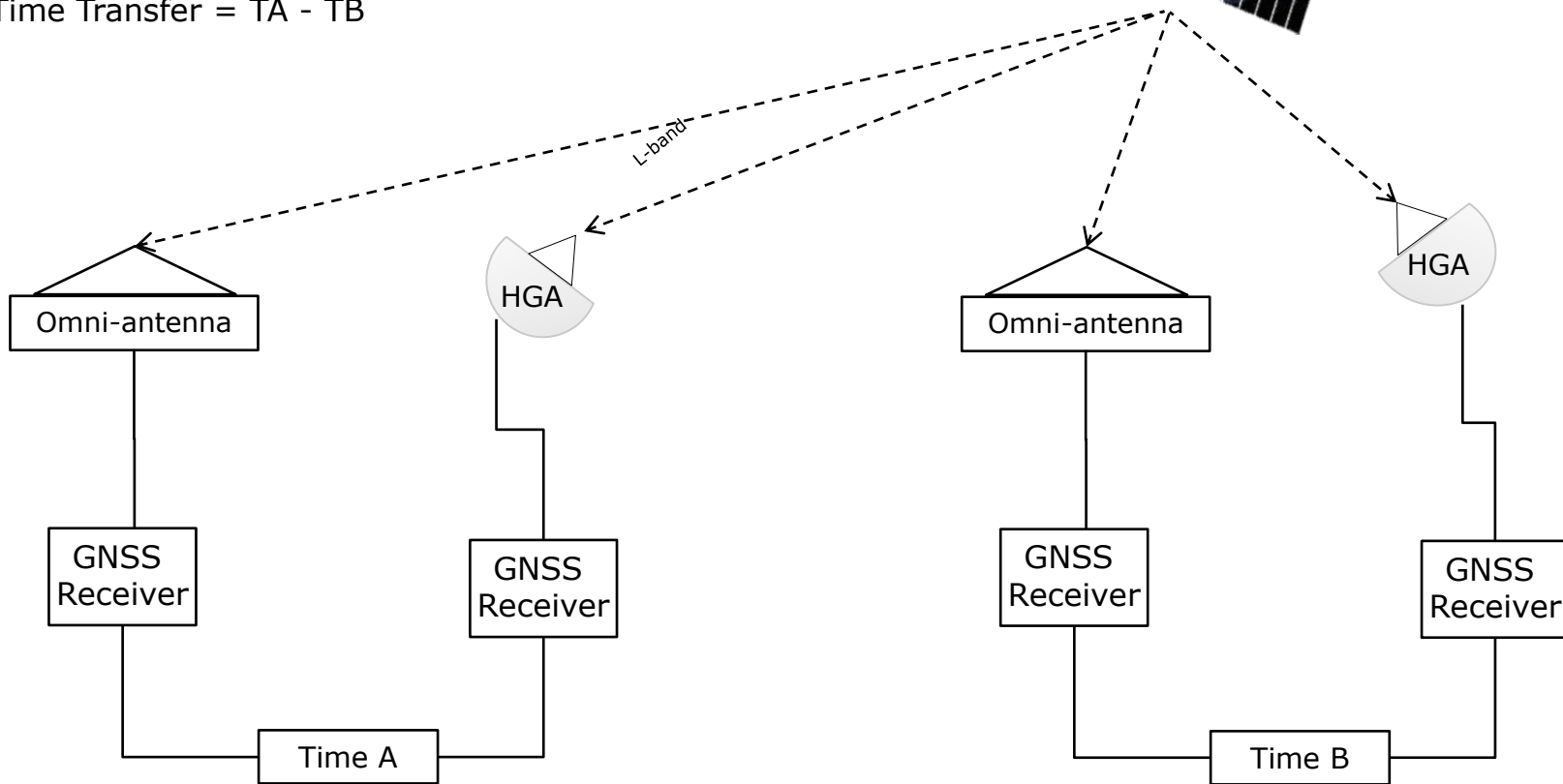
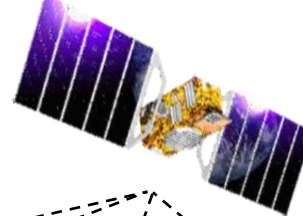

Motivation and challenges

- Motivation: To study the benefits of using directional High-Gain Antennas (HGAs) for metrological GNSS time transfer
- Main Benefit: HGA should largely **reduce the noise/multipath error in the GNSS pseudorange**, due to the higher received power or Signal-to-Noise Ratio (SNR)
- Drawback: HGA can only track one satellite at a time, and the antenna must be pointed/steered to the satellite
- Validation
 - ✓ Time transfer between ESA centres in The Netherlands (ESTEC) and Germany (ESOC), separated by ≈ 400 km
 - ✓ Both ESTEC and ESOC realize UTC(ESA) based on hydrogen masers and caesium
 - ✓ HGA time transfer will be validated by means of Precise Point Positioning (PPP) using standard omni-directional GNSS antennas
- The activity is carried out under project *TIGHT* funded by the European Space Agency (ESA)

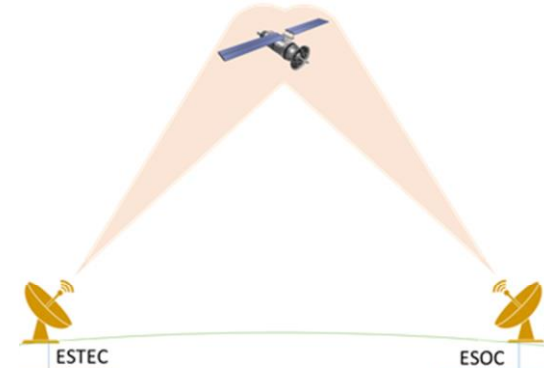

System (1/3) : The antenna

- Two HGA units designed and manufactured by Prodetel near Madrid, Spain, based on affordable **COTS** components:
 - ✓ Antenna anchoring
 - ✓ Steering mechanism
 - ✓ Parabolic reflector (2.4-m diameter dish)
 - ✓ L-band feed
 - ✓ Ancillary parts
- Benefits: high gain and directivity
 - ✓ Antenna gain is 30 dBi, resulting in at least 65 dBHz in terms of receiver CNO (SNR), as compared to 4 dBi and 50 dBHz (max) using omni antennas.
 - ✓ Constant gain and no direction dependent group delay
- Some **limitations**:
 - ✓ Not full motion (Azimuth: 90° to 270°; Elevation: 5° to 90°)
 - ✓ Azimuth and elevation axes do not cross at a fixed point: geometrical transformation needed.

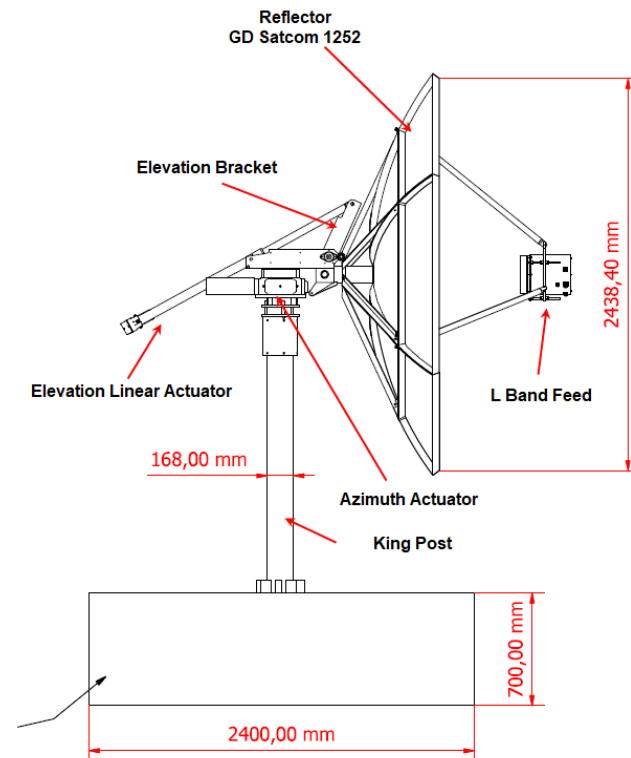

System (2/3): The antenna reference points

- Antenna Reference Point (**ARP**): fixed point with respect to Earth, at the top on the mounting mast
- Calibration Reference Point (**CRP**): fixed point with respect to the rotating antenna dish
- CRP is considered as “phase centre” for GNSS measurements
- Simple geometrical transformation to convert from CRP to ARP (function of Azimuth and Elevation)
- ARP position calculated from **RTK** during installation

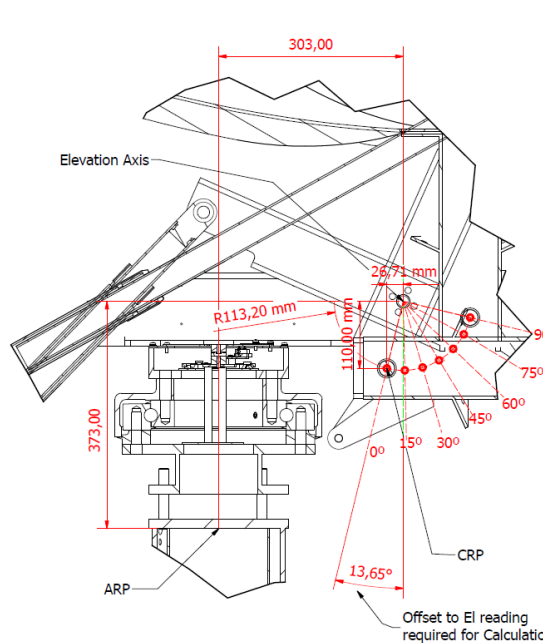

$$\Delta Y(\text{Lat}) = (303 + 113,2) * \sin(EI - 13,65^\circ) * \cos(180 - Az)$$

$$\Delta X(\text{Lon}) = (303 + 113,2) * \sin(EI - 13,65^\circ) * \sin(180 - Az)$$

$$\Delta Z(\text{Alt}) = 373 - 113,2 * \cos(EI - 13,65^\circ)$$

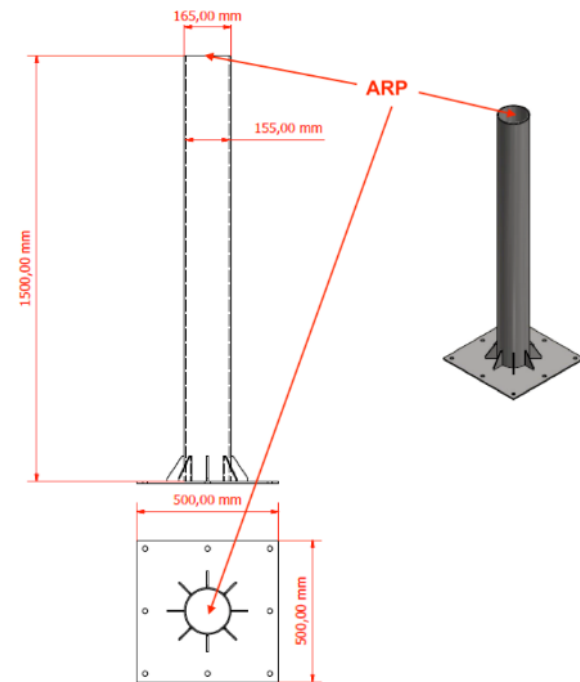

System (3/3): The Receiver

- Septentrio **PolaRx5TR** receiver :

- ✓ COTS
- ✓ Used for Factory test
- ✓ Used for Field test 1st part



- Septentrio **TURN v2** receiver :

- ✓ It is a special receiver developed by Septentrio for Galileo validation
- ✓ SW mostly aligned with Polarx5TR
- ✓ Used for Field test 2nd part onwards
- ✓ Special configuration for High Gain antenna mode
- ✓ E1 CBOC tracking instead of BOC



Factory test (1/5): Pseudorange noise/multipath

- Initial tests in factory (Prodetel) already showed a sharp GNSS spectrum and excellent pseudorange noise/multipath
- Pseudorange noise/multipath evaluated from **CCC** combination (Code-Carrier Coherence)
 - $CCC = P1 + A * L1 + B * L2$
 - $A = (f2^2+f1^2) / (f2^2-f1^2)$; $B = -(A+1)$
- CCC slightly affected by satellite Group Delay Variations (**GDV**) in pseudorange and also by carrier phase noise, which is amplified by factor $F = \sqrt{A^2+B^2}$
- CCC standard deviation in Galileo E5 AltBOC is at the **cm** level

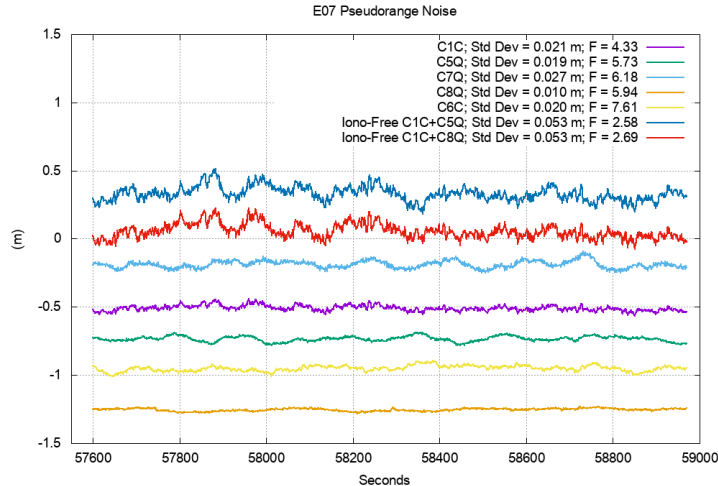
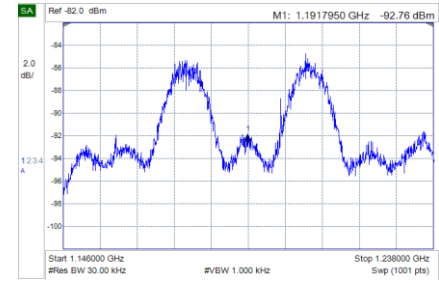
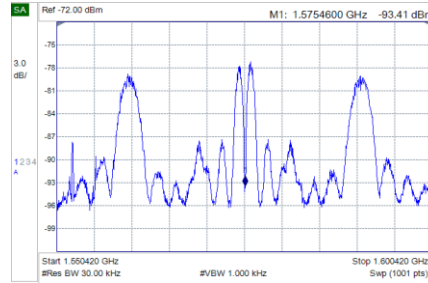

Factory test (2/5): in short baseline and common clock

- Tests conducted with the two HGAs at GMV in Madrid, Spain
- Each chain is connected to a PolaRx5TR receiver
- Pseudorange noise/multipath from CCC is consistent between the two chains
- Typical CCC standard deviation ranges from 15 mm (**50 ps**) in E5 AltBOC to 30 mm (**100 ps**) in E1
- Noise from CCC should be multiplied by $\sqrt{2}$ to consider the combined contribution from two stations in time transfer

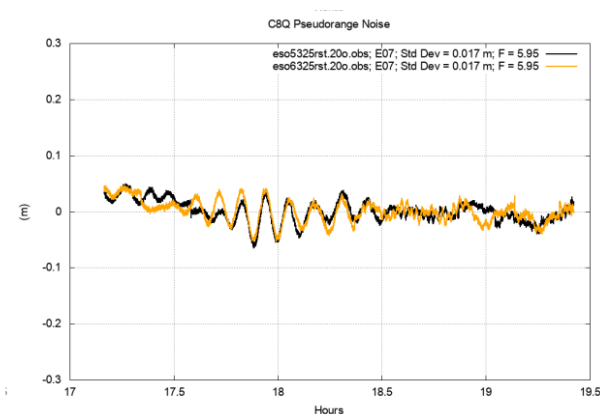
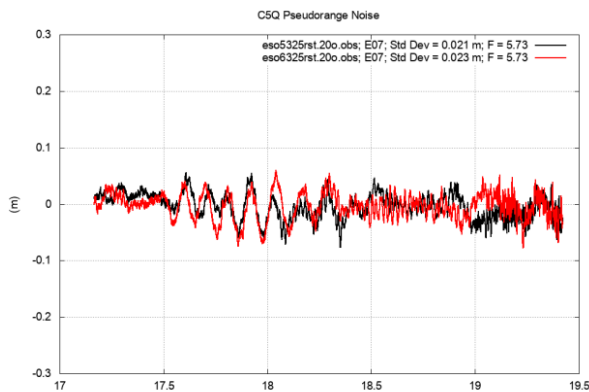
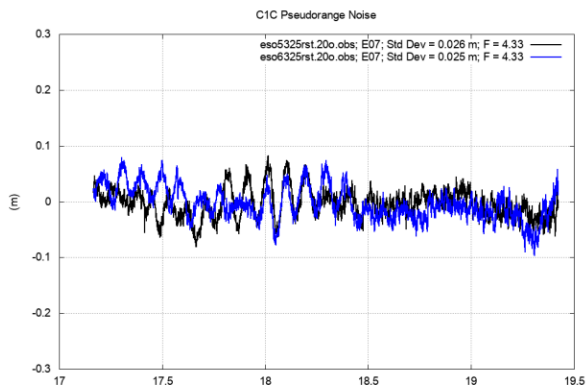

Factory test (3/5): in short baseline and common clock

- **Common-clock calibration** of the two HGA chains shows small differential values but higher-than-expected uncertainty
- Relatively poor repeatability between passes, as compared to the noise/multipath level
- Not a satellite-dependent bias since the jumps are observed in all satellites
- Investigations indicate a receiver effect rather than an antenna issue

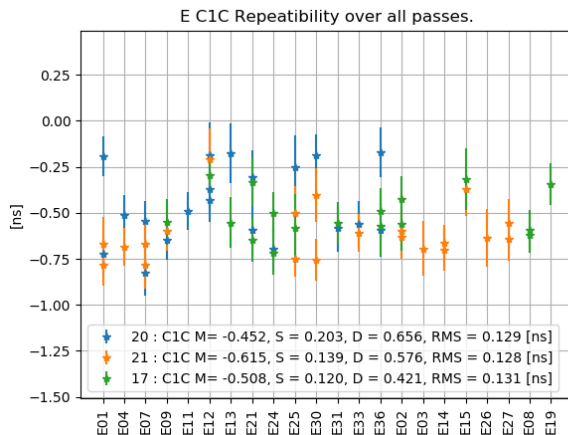

Const.	Signal	Mean [ns]	U (1-σ) [ns]
E	C1C	-0.525	0.187
E	C5Q	-1.172	0.103
E	C7Q	-0.343	0.109
E	C8Q	-0.181	0.102
E	C6C	-0.057	0.105
G	C1C	-0.454	0.221
G	C1W	-0.501	0.373
G	C2W	-0.913	0.106
G	C5Q	-1.180	0.103

Factory test (4/5): in common antenna and clock

- Tests connecting the two receivers to a **common HGA** confirm the presence of small pseudorange “jumps” between passes and also within the same pass (sometimes)
- The effect is also observed when using two receivers connected to an **omni**-directional antenna (best observed in E5 AltBOC due to smaller noise)
- This seems to confirm that the problem is not in the HGA

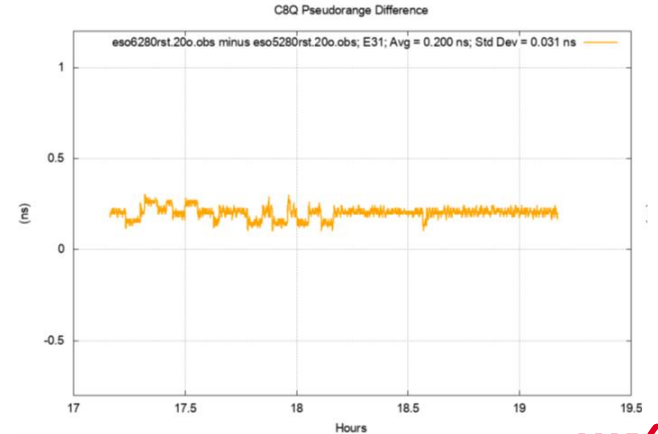
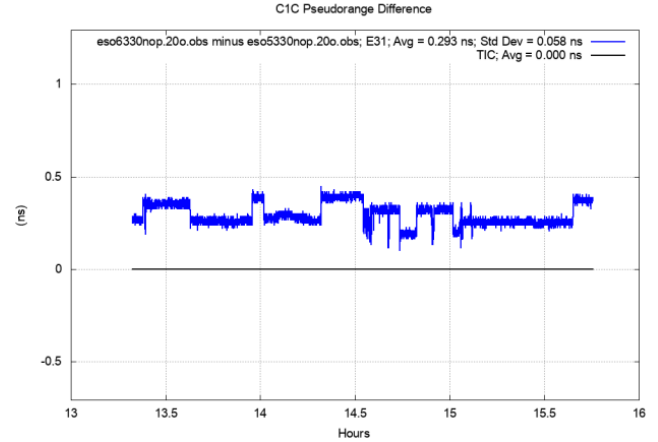
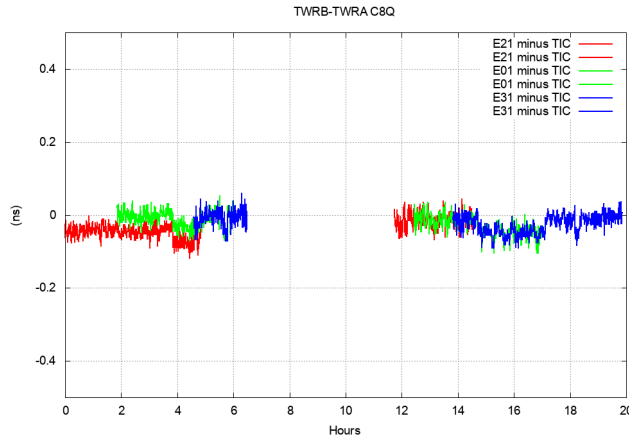

Factory test (5/5): in short baseline and different clock

- Short-baseline **time transfer** with each HGA chain connected to a steered Passive Hydrogen Maser (**PHM**)
- Uses common-clock calibration values
- Good agreement between GNSS and Time Interval Counter (**TIC**)
- Inconsistency between GNSS and TIC up to **200 ps** for some signals
- This confirms pseudorange jump issues

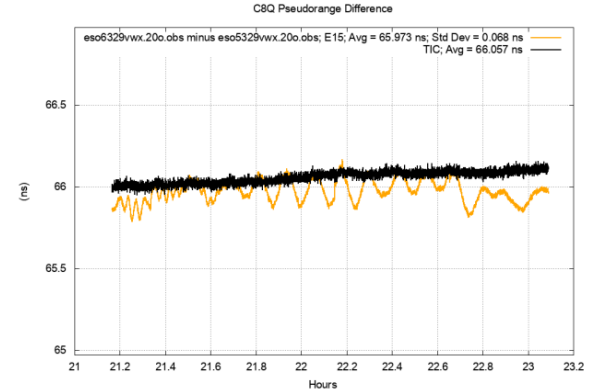
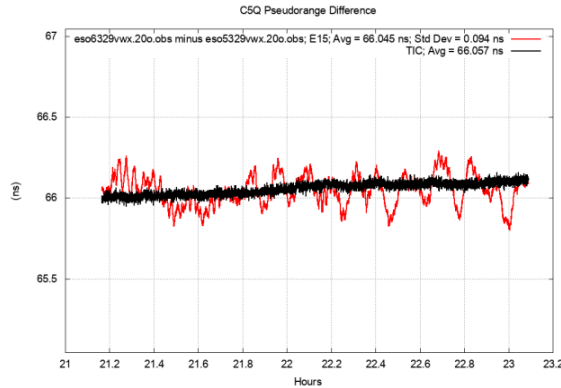
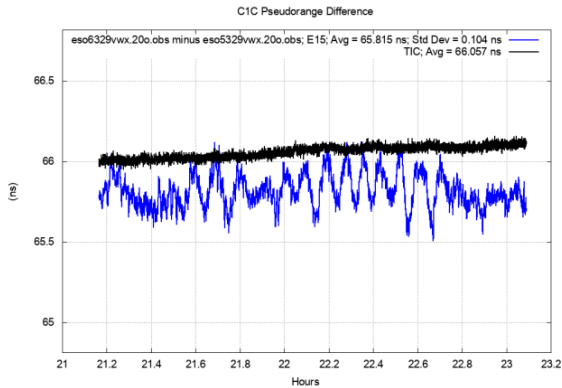

Field test (1/3): Time transfer between ESTEC and ESOC

- Installation of HGAs at ESTEC and ESOC completed and **operational**
- Fully automated processing based on Two Line Element (**TLE**) scheduling and antenna pointing
- Uses **common-clock calibration** values previously obtained at GMV (corrected by different cable lengths)
- Time transfer uses standard CGGTTS files (only format change is REFSYS in ps)
- Updated R2CGGTTS software includes ARP-to-CRP transformation, Galileo GVDs, tropo from PPP solutions, and 1-ps resolution in REFSYS
- Nominal HGA solution is standard **iono-free** E1/E5a
- Two **PPP** solutions available for validation, one from ESTEC and one from ESOC



Field test (2/3): Time transfer using Polarlx5 receiver

- “**TIGHT**” means HGA solution using iono-free E1 and E5a (both at 30s and 16m)
- “**GPS/GAL CV**” is nominal GNSS solution using omnidirectional antennas (CGGTTS at 16 m resolution)
- “**ESA PPP**” means PPP solution from ESTEC
- “**ESOC PPP**” means PPP solution from ESOC (actually not a PPP but a network solution)
- Good agreement between HGAs and PPPs. Iono-free noise amplification in HGA solution is clearly visible, but noise level at 16 m is very good.
- **~2.5-ns offset** between HGA solution and PPPs, just within the combined calibration uncertainty

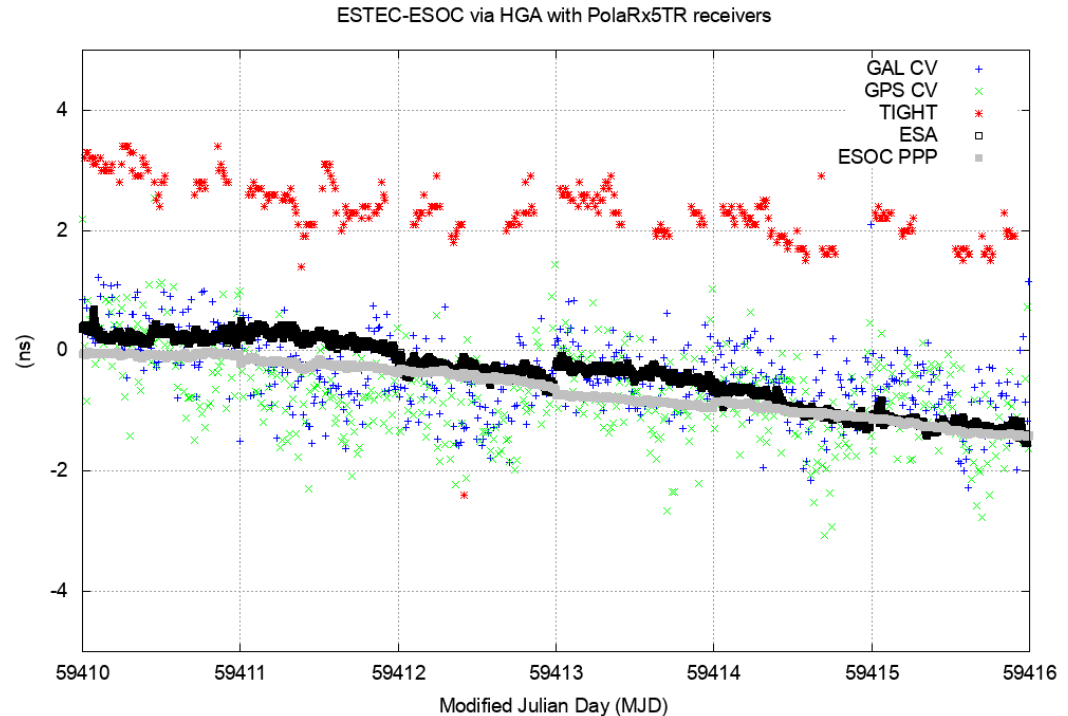

Field test (3/3): Time transfer using TURN v2 receivers

- PolaRx5TR receivers have been recently replaced by **TURNv2** receivers
- Results show a much **better pass to pass repeatability** and no pseudorange jump issues
- **Better continuity** between passes as no need to remove observations
- Unfortunately common-clock calibration was not possible
- Relative **receiver-only calibration** was done at ESTEC lab in common clock and common antenna.
- Difference between TIGHT and ESA calibration still around ~ 3 ns

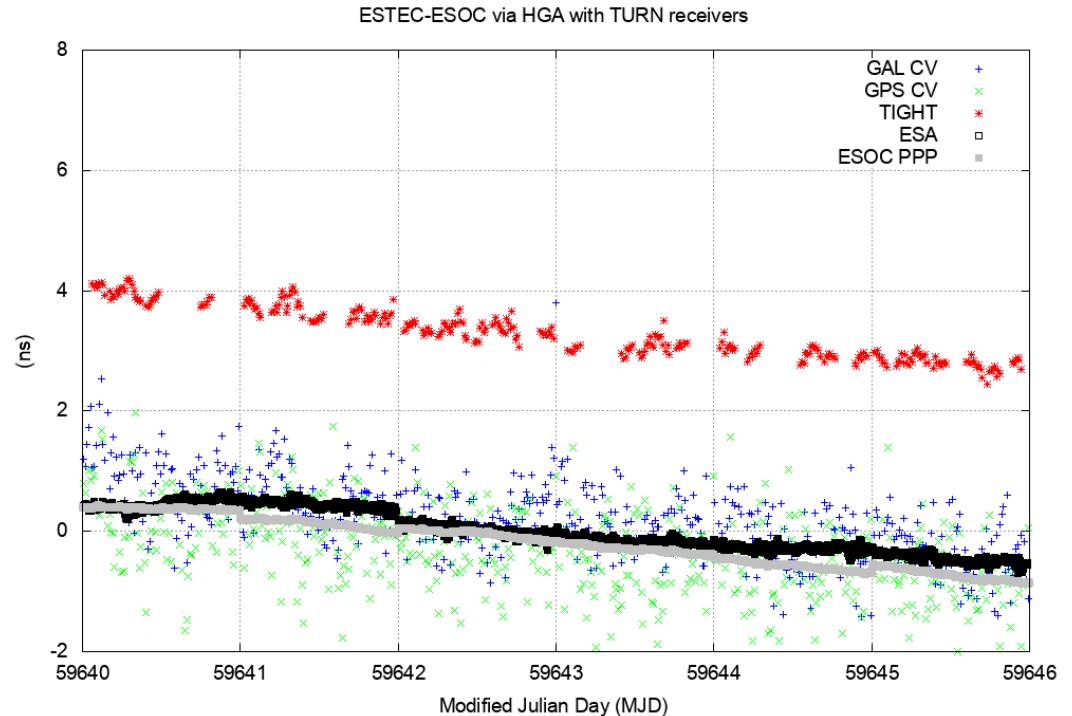

Time transfer error budget (1/2): from relative calibration

- Budget for ESTEC-ESOC time transfer, in ps at 1 sigma
- Nominal **calibration** based on common-clock time transfer with the two HGAs at GMV
- Effect of Galileo **orbit** errors very small (11 ps) due to excellent broadcast ephemeris and short station baseline: no need for precise products
- Galileo satellite GDV can be modelled/corrected from ANTEX file provided by ESA
- Limiting factor could be the residual **tropospheric** delay, possibly to be improved using PPP results
- As is well known, the **iono-free** combination amplifies the calibration uncertainty and the noise/multipath by a factor of almost 3 (GDV effect is also amplified)

	Uncertainty (1-sigma, ps)					
	GPS P1	GPS P2	GPS P3 (iono-free)	Galileo E1	Galileo E5 AltBOC	Galileo E3 (iono-free)
Common-clock calibration	370	106	956	180	100	442
Temperature Effect	50	50	50	50	50	50
Antenna Cable Installation	70	70	70	70	70	70
Systematic Uncertainty (Type B)	380	137	960	199	132	450
HGA phase centre position error	28	28	28	28	28	28
Pseudorange noise and multipath	150	136	436	129	79	320
Residual orbit error (broadcast)	40	40	40	11	11	11
Residual Ionospheric error	?	?	0	?	?	0
Residual tropospheric error ("STANAG")	100	100	100	100	100	100
Satellite antenna GDVs (uncorrected)	30	30	30	30	30	30
Statistical Uncertainty (Type A)	189	178	451	169	134	338
TOTAL Uncertainty	424	225	1061	261	188	562

red: Ionospheric error not considered

Time transfer error budget (2/2): Validation overview

Time Transfer Accuracy

Initial validation of absolute calibration matches expected uncertainty. Differences between the relative calibration from TIGHT and the BIPM calibration, are on the limit of the uncertainty.

Time Transfer Comparison [ns]	Value	Noise	U1 (1- σ)	U2 (1- σ)	Total U (1- σ)
TIGHT - ESA PPP [TURN]	3.4	0.2	0.5*	2.7	~2.75
TIGHT - ESA PPP [PolaRx5TR]	2.9	0.3	0.5	2.7	2.75

*should be increased due to calibration transfer between receivers

Solution Noise

Obtained precision is according to the expectations. TIGHT solution improves ~3-4 times the noise of the traditional code-based CVTT

Solution Precision	Noise (ps)
GNSS CV code based (@16 min)	500
TIGHT code based (@30s)	350
TIGHT code based (@16m)	150
PPP phase based	< 100

Time transfer error budget (2/3): absolute used as validation

- The full antenna calibration can be obtained by means of careful emulation with specialized software.
- Initial result of the full antenna calibration values, **show a promising agreement** with respect to BIPM calibrations (<1ns).
- Initial validation of absolute calibration matches expected uncertainty.
- Differences between the relative calibration from TIGHT and the BIPM calibration, are on the limit of the uncertainty.



Calibrations	L1	L5	U1 (1- σ)	U2 (1- σ)	Total U (1- σ)
Abs Difference ESTEC (BIPM) - HGA CH1	0.97	0.72	1.1	1*	1.49
Relative Calibration (at GMV) - Transferred Omnidirectional (from BIPM)	-1.5	-0.64	0.45	1.6	1.62

* Value for the antenna measurement still under assessment

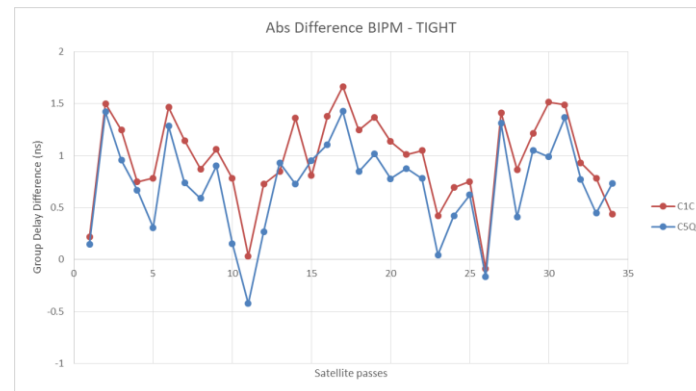

Conclusions

- **First prototype** of HGA time transfer
- ESTEC-ESOC HGA time transfer is fully operational and **automated**
- Simple implementation: standard **CGGTTS** files are used, with minor format modifications
- Low noise: HGA provides pseudorange noise/multipath at the **few-cm** level
- Reduction in noise allows understanding possible receiver limitations for high-accuracy GNSS time transfer (e.g., jumps in pseudorange tracking)
- Advanced **TURN** receivers are currently being used for better understanding of all effects
- Routine HGA results match quite well operational **PPP** results, with a calibration offset which is under study
- The addition of a open service wideband signal in the E1/L1 band would greatly help reducing even more the noise of the code-based iono-free solution.

Thank you

Esteban GARBIN and Ricardo PIRIZ, GMV; Daniel GARCIA, Prodetel; Francisco GONZALEZ, Erik SHOENEMANN, Cedric PLANTAARD, Gwendolyn LAEUFER and Pierre WALLER, European Space Agency (ESA)

Finding the source of the calibration offset

Many different calibration sources has been used in the project:

- **Relative full chain** calibration at GMV premises.
- **Relative receiver only** calibration for TURN receivers.
- **Absolute receiver calibration** value for PolaRx5TR receivers.
- **Absolute calibration** for the HGA antenna.

The difference of **3.1 ns** between the two time transfer solutions cannot be explained by the expected uncertainty of the relative calibration.

An analysis of the absolute calibration achievable with the HGA is being performed.

- **Absolute calibration** of the full antenna was originally intended. A test was performed, but several problems rose that generated very big uncertainty.
- To follow-up on this task, **feed-only absolute calibration** was proposed.

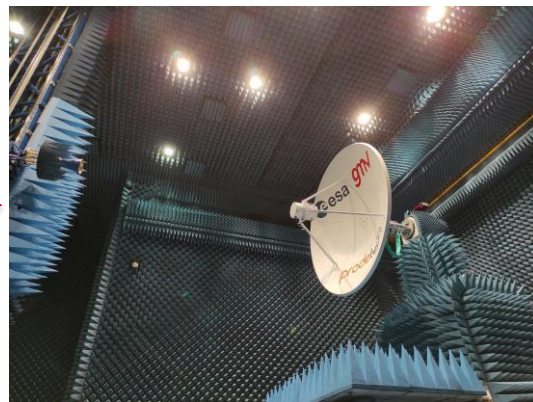
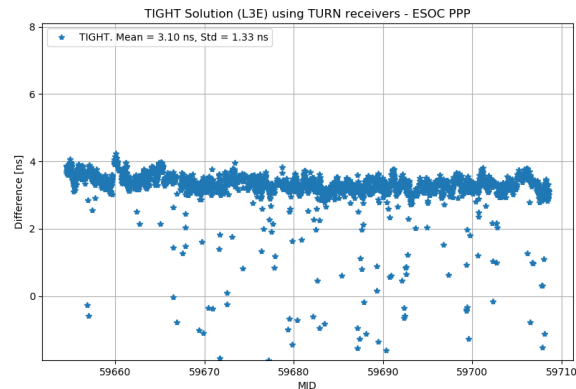

Effect of satellite Group Delay Variations (GDV)

- Galileo satellite antenna GDV calibrated by ESA and provided in **ANTEX** format (under validation)
- GDV implementation requires interpolation from ANTEX file, plus satellite and Sun ephemeris
- Plot below shows GDV from ESTEC and ESOC for Galileo E5 AltBOC, from ANTEX file
- Differential effect is quite small for the ESTEC-ESOC baseline
- Iono-free combination also amplifies the GDV mis-modelling
- Total ESTEC-ESOC effect is evaluated to be around **50 ps** 1-sigma in iono-free even with GDV uncorrected

